

The CDI G40 Stationary free standing skid mounted Screen is built to last with its Heavy Robust construction. It is designed to be fed directly by a standard Skid steer or wheel loader. The CDI G40 is fitted with an aggressive 2 bearing screenbox which can be adjusted in speed, amplitude and direction to suit all application needs to obtain maximum efficiency.

Applications

- Topsoil
- Compost
- Crushed aggregate.
- Sand & Gravel.
- Coal.
- Hard Rock.
- Limestone.
- Most others!

Affordable Screening!
Fast Setup Time!
Low maintenance costs!
Low running costs!

Transport Mode
Is
Operating mode!



Features

- Transported in one piece. (loaded via standard Forklift)
- Bolt on Feed hopper. (2.6m x 650mm)
- Fully Guarded to BS7300.
- 4 or 5.5kw Geared Direct Electric drive system.
- All bearing grease points accessible from ground level.

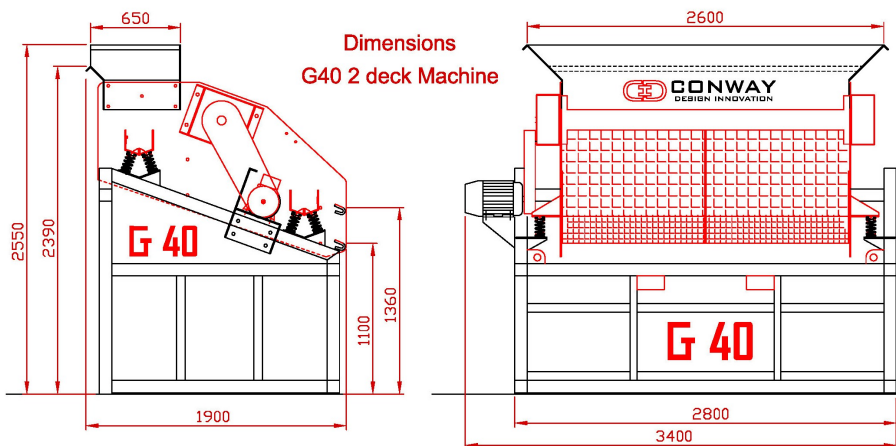

Standard Specification:

Machine Weight: Approx. 1.65 Tonne. (Basic Spec)
Electric drive system: (4kw single phase or 5.5kw 3 phase 50hz)
Output: Up to 200 TPH depending on material and application.
Inlet Feed height: 2.2m as shown.
Inlet Feed width: 2.6m as shown.
Screenbox size : 2.1m wide x 1.8m long inside. (Bi-Directional)
Mesh media size: 2 no 1.05m x 1.8m end tensioned mesh panels.
Mesh media types: Woven wire, Piano wire, Self Cleaning mesh and HD welded mesh.

Options

- Leg Extensions to increase discharge heights.
- Hydraulic Drive system. (requires external hydraulic oil supply)
- 2 No Screening decks. (Single Deck is Standard)

Website: www.cdi-ltd.com **Email:** Sales@cdi-ltd.com

Moved and loaded via Forklift

CONWAY DESIGN INNOVATION LTD

1A Killybrack Mews
 Omagh, Co Tyrone
 BT79 7FB
 Co reg: NI 660645
 VAT No: 323 6254 22
 Tel. No. (+44) 2882 240611