

Introducing maximum unrivalled mobility & unique zero set up time "operating mode is transport mode". The CDI S10 is fitted with an aggressive 2 bearing screenbox which can be adjusted in speed, amplitude and direction to suit all application needs for maximum efficiency.



Applications

- Topsoil & Compost
- Demolition
- Crushed stone
- Sand & Gravel
- General landscaping



Transport on Car Trailer

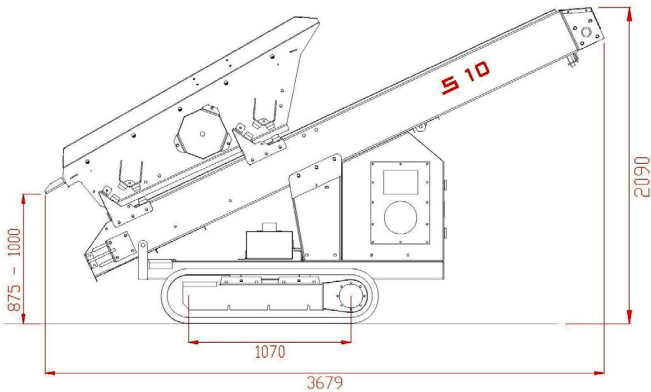

Dimensions **Max Width: 1.55m**

Technical Specifications

- Machine Weight:** Approx. 1.9 Tonne (Basic Spec)
- Output:** Up to 40 TPH
- Power unit:** 15 Kw Diesel/Hydraulic (Onboard)
- Tracks:** 200mm (9") wide Rubber
- Discharge conveyor:** 750mm wide (fully skirted)
- Screenbox size:** 1.52m x 0.9m (5' x2'10") (single deck Std)
(Optional 2 Deck version also available to maximise fines output)

Controls

- Engine:** Start/stop with manual throttle
- Screenbox:** hydraulic on/off
- Discharge Conveyor:** Hydraulic on/off (variable speed)
- Tracks:** Variable speed (Independent forward and reverse)

Features

- Most compact track mounted Screen on the market
- Robust and aggressive 2 bearing screenbox
- No set up time
- High track ground clearance for maximum mobility
- Single side tensioned mesh panel for ease of changing

Options

- 2 deck screenbox.
- Oversized discharged chutes
- Remote Radio track control
- Piano wire cassette tension frame

CDI Ltd
1A Killybrack Mews
Omagh,
Co Tyrone
BT79 7FB

See us Online:
www.cdi-ltd.com
Tel: 0044 2882 240611

Screen in locations you never thought possible!