

Introducing Heavy Duty lasting build and High Precision Screening. The ST range is fitted with a Robust and Very Aggressive two bearing screening mechanism for High performance. All models come standard on a Robust Stepped chassis/subframe with HD 'I' beam construction to withstand high impact loads. The range offers Three model sizes with up to three integrated decks to obtain 4 grades of finished product.

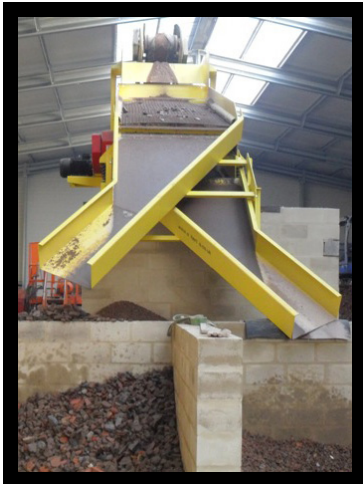

Applications

- Sand
- Gravel
- Rock
- Crushed stone
- Recycling
- Washing plants



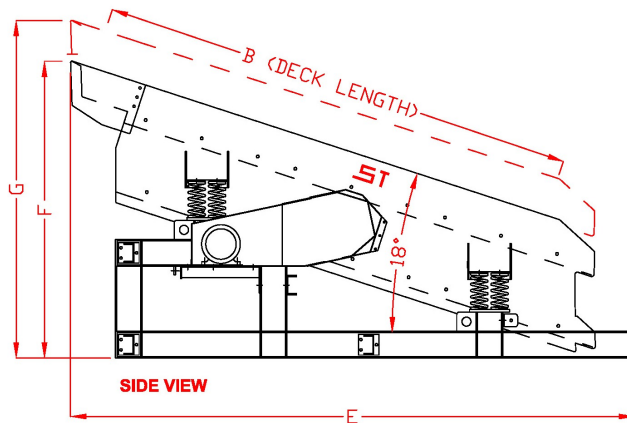
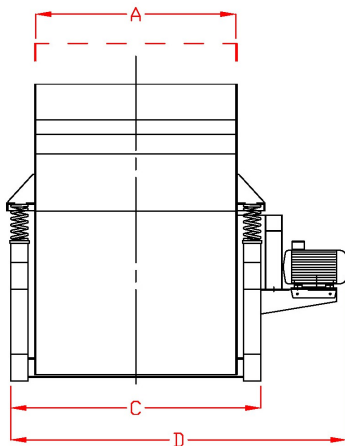

Standard Features

- Outputs up to 500TPH
- Direct Electric Drive
- Side Tensioned Mesh.

Options

- Hydraulic plug Drive
- Full Washing equipment
- Fingers on top deck
- Piano wire cassette frame
- Discharge chutes to suit

Dimensions

MODEL NAME	5ft A	B	C	D	E	F	G
10ft ST 50	1550	3000	1940	2600	3900	2200	N/A
12ft ST 60	1550	3700	1940	2600	4400	2300	2600
16ft ST 80	1550	4900	1940	2680	5600	2900	3400

Dealer / Agent

**Contact CDI for details.
(currently enlisting in
select countries)**

The ST Range is ideally suited to rugged conditions in quarrying and mining environments where it can be integrated into the heart of any new or existing processing plant. Bespoke Chutes, structures and washing equipment are also available to suit any application. These special components are designed specifically to suit each individual application by the CDI Engineering Department. This service is available upon request via your local CDI Agent.

CONWAY DESIGN INNOVATION LTD

1A Killybrack Mews
 Omagh, Co Tyrone
 BT79 7FB
 Co reg: NI 660645
 VAT No: 323 6254 22
 Tel. No. (+44) 2882 240611