

H6 3 Cubic M Belt Feed Hopper (6 Tonne)

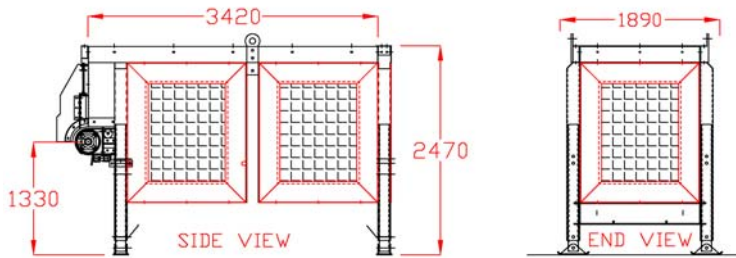

Standard Features

- Up to 300 TPH Output
- 6mm plate hopper sides.
- Transport in one piece.
- 750 belt
- 5.5KW Electric drive.
- Tensioned polyurethane primary scraper.
- Telescopic legs.

Options

- Hopper extensions (increases capacity).
- Bolt on hopper steel liners.
- Fixed angle grid.
- Manual tipping grid.

H12 6 Cubic M Belt Feed Hopper (12 Tonne)

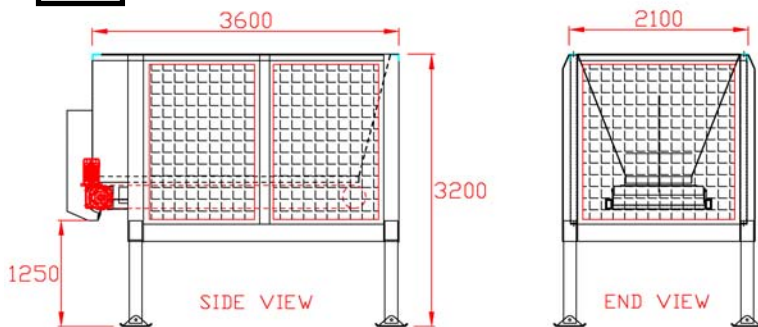

Standard Features

- Up to 450 TPH Output
- 6mm plate hopper sides.
- Transport in one piece.
- 900 belt
- 11KW direct electric drive.
- Tensioned polyurethane primary scraper.
- Telescopic legs.

Options

- Hopper extensions (increases capacity).
- Bolt on hopper steel liners.
- Fixed angle grid.
- Manual tipping grid.

Applications

- Primary Plant Feed
- Crusher and Screener Transfer
- Crushed Aggregates
- Sand and Gravel
- Hard Rock.
- Limestone
- Coal

CDI Ltd
1a Killybrack Mews
Omagh, Co tyrone
N.Ireland. BT797FB
Tel: +44 2882240611
Mob: +44 7961578573

E-mail: sales@cdi-ltd.com.

Note: Smaller and Larger units also available and can Be designed Bespoke to suit your requirements